

modulation sciences, inc

12A World's Fair Drive Somerset, NJ 08873 USA

Voice (732) 302-3090 Fax (732) 302-0206

Toll-free in USA (800) 826-2603

Web: www.modsci.com

Technical Manual

**Model PRO-II
Professional Channel Receiver**

THIS PAGE INTENTIONALLY LEFT BLANK

Table of Contents

CHAPTER 1: SPECIAL FEATURES	5
1.1 INTRODUCTION	5
1.2 NON-INTERCARRIER AURAL RECEPTION	5
1.3 FREQUENCY AGILITY	5
1.4 DIVERSITY RECEPTION.....	5
1.5 SELECTIVE CALLING.....	6
1.6 AUTOMATIC DUCKING OF MAIN CHANNEL AUDIO	6
1.7 POWER SUPPLY OPTIONS	6
1.8 OUTPUTS FOR VARIOUS PURPOSES.....	6
CHAPTER 2: SPECIFICATIONS.....	9
2.1 DIMENSIONS:.....	9
2.2 POWER REQUIREMENTS:	9
2.3 FUSES:.....	9
2.4 TEMPERATURE RANGE:.....	9
2.5 CONTROLS:.....	10
2.6 INPUT/OUTPUT CONNECTIONS:	10
2.7 FREQUENCY COVERAGE:.....	11
2.8 FRONT PANEL INDICATORS:	11
2.9 SENSITIVITY:	11
CHAPTER 3: INSTALLATION.....	13
3.1 MOUNTING.....	13
3.2 POWER CONSIDERATIONS	13
3.3 ANTENNA CONSIDERATIONS.....	13
3.4 CHANNEL SELECTION	14
3.5 CTCSS SELECTION	14
3.6 HEADPHONE LEVEL.....	14
3.7 MAIN CHANNEL LEVEL	15
3.8 PRO CHANNEL LEVEL	15
3.9 DUCKING.....	15
CHAPTER 4: THEORY OF OPERATION.....	17
4.1 ANTENNA DIVERSITY	17
4.2 CHANNEL SELECTION/RF FRONT END	17
4.3 VIDEO	17
4.4 BASEBAND AURAL.....	17
4.5 PRO CHANNEL DETECTION.....	18
4.6 CTCSS	18
4.7 POWER SUPPLY	19
CHAPTER 5: WARRANTY.....	21
5.1 THREE YEARS ON PARTS AND LABOR	21
5.2 MSI WARRANTY POLICY SUMMARY.....	21
5.2.1 Who receives warranty protection?	21
5.2.2 What does the warranty cover?	21
5.2.3 What doesn't the warranty cover?	21

5.2.4	<i>How is the warranty period computed?</i>	22
5.2.5	<i>What if the unit cannot be repaired or is too expensive to repair?</i>	22
5.2.6	<i>How is warranty service obtained?</i>	22
5.3	MSI WARRANTY POLICY	23
CHAPTER 6: DIAGRAMS		25
6.1	PRO-II PROCEIVER--BLOCK DIAGRAM--RF AND VIDEO SECTION	27
6.2	PRO-II PROCEIVER--PRO AND CTCSS SECTION BLOCK DIAGRAM.....	28
6.3	PRO-II PROCEIVER POWER SUPPLY SCHEMATIC.....	29
6.4	PRO-II PROCEIVER DIVERSITY CIRCUIT SCHEMATIC.....	30
6.5	PRO-II PROCEIVER TUNER SCHEMATIC.....	31
6.6	PRO-II PROCEIVER VISUAL IF SCHEMATIC.....	32
6.7	PRO-II PROCEIVER AURAL IF SCHEMATIC.....	33
6.8	PRO-II PROCEIVER CPU BOARD SCHEMATIC.....	34
6.9	PRO-II PROCEIVER SECTION INTERCONNECTS.....	35
6.10	PRO-II PROCEIVER PINOUT--12 VDC POWER CONNECTOR.....	36
6.11	PRO-II PROCEIVER RF BOARD PICTORIAL	37
6.12	PRO-II PROCEIVER CHANNEL TUNING CHART	38
CHAPTER 7: PARTS LISTS		39

Chapter 1: Special Features

1.1 Introduction

The Modulation Sciences PRO-II PROceiver is an affordable, self-contained PRO channel receiver ideal for television ENG and EFP operations. The PRO-II PROceiver frees television stations from excessive cellular telephone bills by allowing the use of the PRO channel on the TV station's aural carrier for cueing and IFB. A video output suitable for driving picture and waveform monitors is also available.

1.2 Non-Intercarrier Aural Reception

The PRO II PROceiver does not depend on intercarrier detection for recovery of the main and PRO aural channels. It is completely immune to ICPM and contains internal SAW filtering to protect the aural signal from video interference, offering freedom from the annoying buzz that sometimes accompanies contrasty scenes. Non-intercarrier aural detection extends coverage of the PRO channel and the main aural channel well beyond that of regular picture coverage.

1.3 Frequency Agility

The PRO-II PROceiver features a stable synthesized tuner which receives any North American TV channel from 2 through 69. An internal DIP switch allows the customer to program the PROceiver to receive any TV channel within this range.

1.4 Diversity Reception

The PRO-II PROceiver includes a two-input antenna diversity system. "A" and "B" antenna input connectors are provided. An antenna is selected dynamically on the basis of minimum multipath and maximum signal strength. Switching time is under 10 microseconds. Unless there is frequent switching back and forth, the switching is inaudible. However, switching is not synchronous with video so "sync rolls" are possible with diversity operation. A front panel switch defeats the diversity feature and holds the PROceiver on the "A" antenna input.

Diversity is important for ENG/EFP operations because of multipath. Everyone has had the experience of hearing "picket fencing" while listening to FM radio in a moving car, particularly in a mountainous area or in the concrete canyons of a large city. Or, the audio is distorted when the car is stopped at a traffic light. These are classic examples of

multipath. In the case of the stopped car, the cure is to roll the car a few inches. The audio then clears up. The same multipath affects PRO channel operations. However, if the microwave mast is extended, it is not possible to roll the van a few inches. The solution is to use a second antenna, mounted as far horizontally from the main antenna as is practical. A simple whip antenna will work well in most areas and it need not be resonant. This will be discussed in more detail in the INSTALLATION section of this manual.

1.5 Selective Calling

The PRO-II PROceiver features a CTCSS tone-controlled squelch system for unmuting the PRO channel audio. When used with our PCG-II PRO Sidekick Generator, stations may signal individual field units.

1.6 Automatic Ducking of Main Channel Audio

On live broadcasts, the PRO-II PROceiver allows ENG crews to listen to full-fidelity audio on the main aural channel when no cues or IFB audio are being sent to them on the PRO channel. When the crew's PROceiver is addressed, the volume of the main program audio is pushed down ("ducked") and the PRO channel audio becomes dominant. The amount of ducking can be preset by the customer with a simple screwdriver adjustment.

1.7 Power Supply Options

As supplied, the PRO-II PROceiver will operate directly from 117 VAC, 230 VAC (50 to 400 Hz), or 12 VDC. Selection of either 117 or 230 VAC is made by flipping a small plug-in circuit card in the IEC filtered AC power connector. Connection for 12 VDC operation is made through a Molex[®] connector on the rear of the unit. Current consumption is less than 500 mA. The PROceiver will operate from 11.5 to 16 VDC. An avionics rated power supply is available for operation from an aircraft 28 VDC bus. This is normally a factory-installed option that replaces the 12 VDC capability. Field installation is possible but not recommended.

1.8 Outputs for Various Purposes

Two XLR connectors on the rear of the PRO-II PROceiver provide balanced, line-level audio. One always carries main channel program audio. The other XLR connector carries the IFB signal. Depending on how the internal controls of the PROceiver are set this may be PRO channel audio only or full-fidelity main channel audio ducked under the PRO channel audio whenever that receiver is addressed.

A quarter-inch headphone jack is provided on the front panel. This is a low-impedance output, which normally carries unswitched, unsquelched PRO channel audio regardless of

whether or not the CTCSS tone for that receiver is being transmitted. A push button on the front panel switches the output to main channel audio when pressed.

NOTE: The headphone jack is a three-wire jack (tip, ring, sleeve). It is wired so that either a three-wire stereo plug or a two-wire monaural plug will work. Each of the active terminals, tip and ring, is connected to the driving amplifier through individual build-out resistors. Thus, stereo headphones will receive equal level in both ears. If a monaural headphone plug is inserted, the audio signal at the ring terminal of the jack will be grounded by the sleeve of the plug. However, since the tip of the headphone jack is driven by its own resistor, audio will remain available. The level will be reduced somewhat by the grounded resistor but the loss will not be excessive.

A BNC connector on the rear panel of the PROceiver provides a 2 volt peak-to-peak composite aural baseband signal. This signal can be used to drive a stereo audio decoder such as our SRD-1 Stereo Reference Decoder or a modulation monitor such as our TVMM-1 TV ModMinder. This output is fully buffered. Not even an accidental short on this output will affect the normal operation of the PROceiver.

A standard video output, suitable for driving picture and waveform monitors, is available from a BNC connector on the rear panel of the PROceiver.

The 25-pin D connector on the rear panel of the PRO-II PROceiver is not wired to anything at this time. It is intended for future options.

THIS PAGE INTENTIONALLY LEFT BLANK

Chapter 2: Specifications

2.1 Dimensions:

Occupies one (1) rack unit.

SIZE (H x W x D):

Front panel:

1.75" H x 19.0" W

44.45 mm H x 482.6 mm W

Chassis:

1.55" H x 16.75" W x 11.45" D

39.37 mm. H x 425.5 mm W x 176.33 mm D

2.2 Power Requirements:

110 to 130 VAC, 14 Watts, 50 to 400 Hz

11.6 to 16 VDC, 500 mA

208 to 240 VAC available as user-selectable option

28 VDC, 250 mA available from factory as option

2.3 Fuses:

0.25 A slow-blow (115 volt operation) on IEC connector

0.15 A slow-blow (230 volt operation) on IEC connector

1 A fast-blow (12 volt DC operation), mounted internally in power supply section

2.4 Temperature Range:

-10 to 50 degrees C

2.5 Controls:

Front Panel:

Antenna Diversity on/off

Headphone Switch (Main/PRO channel audio)

Rear Panel:

AC line voltage selector (part of IEC connector)

Internal:

CTCSS Tone Select (DIP switch)

Channel Select (DIP switch)

Headphone Level (screwdriver adjustment accessible from top cover)

Main Level (screwdriver adjustment accessible from top cover)

Duck Level (screwdriver adjustment accessible from top cover).

2.6 Input/Output Connections:

HEADPHONE:

Quarter-inch stereo phone jack on front panel

Low-impedance output

AC POWER:

Standard IEC three-conductor AC line connector on rear panel

DC POWER:

2-conductor Molex[®] connector on rear panel

AUX:

25-pin female D connector (not used; intended for future options)

MAIN PGM OUT:

Male XLR connector on rear panel

Balanced line-level output, 600 ohms

PRO AUDIO OUT:

Male XLR connector on rear panel

Balanced line-level output, 600 ohms

COMPOSITE OUTPUT:

BNC connector on rear panel, 2 volts peak-to-peak

VIDEO OUTPUT:

BNC connector on rear panel, standard 75 ohm output

DIVERSITY ANTENNA INPUTS:

Two (2) BNC connectors on rear panel. Use the A input for non-diversity operation.

2.7 Frequency Coverage:

North American TV Broadcast channels 2-69. User-selectable through DIP switches inside receiver. Other channel tables may be accommodated on special order.

2.8 Front Panel Indicators:

ANTENNA DIVERSITY: A (green LED), B (amber LED)

CARRIER: Main (green LED), PRO (amber LED)

MODULATION: CTCSS (red LED), PRO (amber LED)

2.9 Sensitivity:

Main channel:

-90 dBm or better for 20 dB of quieting

-103 dBm or better for -12 dB SINAD

PRO channel:

-95.5 dBm or better for -12 dB SINAD

THIS PAGE INTENTIONALLY LEFT BLANK

Chapter 3: Installation

3.1 Mounting

The PRO-II PROceiver is built in a steel box which occupies one rack unit (1.7 inches / 43.18 mm). For strength, the rack ears run the depth of the box. The rack ears are attached by threaded studs on the box. To mount the PROceiver outside of a rack, remove the rack ears. Angle brackets may be fabricated to secure the PROceiver to any flat surface.

3.2 Power Considerations

As supplied, the PRO-II PROceiver will operate directly from 117 VAC, 230 VAC (50 to 400 Hz), or 12 VDC. Selection of 117 or 230 VAC is made by flipping a small plug-in circuit card in the IEC AC connector at the rear of the unit. Connection for 12 VDC operation is made via a Molex[®] connector on the rear of the unit. Current consumption is less than 500 mA. The acceptable voltage range is from 11.5 to 16 volts. If you are powering the PROceiver from a battery, we recommend that you fuse the supply line near its source. Fuse value should be 1 A. The PROceiver has an internal 1 A DC fuse.

An avionics rated power supply is available for operation from an aircraft 28 VDC bus. This is normally a factory-installed option that replaces the 12 VDC capability. Field installation is possible but not recommended.

3.3 Antenna Considerations

The PRO-II PROceiver features a two-input diversity reception system. An antenna input is selected dynamically on the basis of minimum multipath and maximum signal strength. Switching time is less than 10 microseconds. Unless there is frequent switching back and forth, this switching is inaudible. However, switching is not synchronous with video, so a sync roll is possible with diversity operation. If desired, diversity reception may be defeated by a front panel switch. This holds the receiver on the "A" antenna input.

Diversity reception is used for mobile operation, as it minimizes the "picket fencing" effect that plagues mobile FM radio reception. If an ENG/EFM van is parked in a spot where multipath is bad, the diversity feature will clean up the audio and reduce ghosting in the picture.

There are several options for a main antenna. Usually, this antenna is mounted on

the microwave mast. RV “pancake” antennas are popular in ENG operations. These are horizontally polarized, directional antennas that contain active amplifiers. They work well, but the RF amplifier is untuned and easily burned

out. RF from the communications transmitters on emergency vehicles often found at news locations will destroy the antenna amplifier in a few seconds. If your channel is high enough that the antenna is not too big, a mast-mounted Yagi may be preferable to a “pancake” antenna.

The type of antenna used for the “B” input is not critical. A vertical whip may be used satisfactorily, even if the station is not circularly polarized. Under multipath conditions, polarization of a VHF or UHF signal is random. Since the “B” input is usually used under multipath conditions, the polarization of this antenna is unimportant. Length of this antenna is not critical. It need not be resonant. Be sure to mount the “B” antenna as far as possible horizontally from the main antenna.

3.4 Channel Selection

Broadcast channel selection is made via a DIP switch on the CPU board. The two digits of the channel are selected by two BCD codes. Then, the low VHF (Channels 2-6), high VHF (Channels 7-13), or the UHF band is selected by the DIP switch. After the selections are made, press the RESET button on the CPU board to tune the receiver to the desired channel. PROceivers are **not** shipped preset to the user’s channel. To aid in setting the PROceiver to the proper channel, a diagram of the settings for all channels is included in Section 6.12 of this manual and on the inside of the top cover of the unit.

3.5 CTCSS Selection

Selection of a CTCSS tone frequency for selective calling or disabling of the selective calling feature is accomplished by a DIP switch on the PRO board of the PROceiver. The DIP switch may be set to any one of 16 CTCSS tone frequencies or to “receive all”. A diagram of the settings for each CTCSS frequency and for disabling the selective calling feature is featured in Section 6.12 of this manual and on the inside front cover of the unit. All PROceivers are shipped with selective calling disabled.

3.6 Headphone Level

The audio level in the headphones may be set to a comfortable level through the HEADPHONE LEVEL control. This is a screwdriver adjustment accessible through a hole in the top cover.

3.7 Main Channel Level

The output level at the MAIN PGM OUT XLR connector on the rear panel may be adjusted by the MAIN CHANNEL control. This is a screwdriver adjustment accessible through a hole in the top cover.

3.8 PRO Channel Level

To adjust the level of the PRO channel audio to the PRO AUDIO OUT XLR connector on the rear panel, adjust the LINE LEVEL (RV 2) control. This is a screwdriver adjustment on the PRO board. It is not accessible from the outside of the unit.

3.9 Ducking

This controls the amount of main channel program material heard with the PRO channel audio when an IFB or cue signal is being received. The ducking feature works on the PRO AUDIO OUT output. Ducking is adjusted through the DUCK LEVEL control, a screwdriver adjustment accessible through a hole in the top panel of the unit. The main channel audio may be turned completely off if desired. This is useful if the audio being transmitted on the PRO channel is unrelated to the main program.

THIS PAGE INTENTIONALLY LEFT BLANK

Chapter 4: Theory Of Operation

4.1 Antenna Diversity

The diversity circuit is located on the RF circuit board. The PRO-II PROceiver has two antenna inputs, A and B. The main receiving antenna is connected to the A input and the auxiliary antenna to the B input. These enter solid-state switch IC 8. AGC voltage from FM detector/IF amplifier IC 2 and composite aural from IC 2 are routed to antenna diversity circuits IC 4 and IC 9. IC 4 and IC 9 provide a control signal for IC 8, toggling the switch between input A and input B, whichever provides the strongest signal with the least noise and multipath distortion. The output of IC 8 is then fed to the tuner module. The ANTENNA A switch, when turned on, holds the control input of IC 8 high, defeating the diversity feature and routing the input A signal to the tuner.

4.2 Channel Selection/RF Front End

Switched RF from IC 8 enters the TVS-467 high-quality synthesized tuning module. The tuner is programmed by U2 on the CPU board. Three sets of binary switches program U2. One set of two poles determines the band (low VHF, high VHF, or UHF). The other two sets of four poles determine the channel number. The RESET button on the CPU board is used to select the desired channel. It is debounced through U1.

4.3 Video

All video circuitry is located on the RF circuit board. The visual IF output of the tuner enters FL2, which is a dual SAW filter. From there, it is detected in the video detector section of TV demodulator circuit IC 10. The video output is amplified in IC 11 and passes through a bandpass filter consisting of C67, C68, L9, and L10. The output of IC 11 appears at the VIDEO BNC connector on the rear panel. IC 10 also develops an AGC voltage which controls the gain of the RF amplifier in the tuner.

4.4 Baseband Aural

All baseband aural circuitry is on the RF circuit board. The aural IF output of the tuner passes through dual SAW filter FL2. From there, it enters mixer/oscillator IC 1, where it is heterodyned to 10.7 MHz. This 10.7 MHz second IF is then filtered through an image rejection filter consisting of C6, C7, and L1. The filtered IF is then amplified and the composite aural is detected in FM IF amplifier/discriminator IC 2. IC 2 develops a signal strength reference voltage which is amplified in IC 3A and routed to diversity circuit IC 4 and IC 9. The signal strength voltage also activates the CARRIER LED through LED driver U3 on the CPU board. Composite aural from IC 2 is amplified in IC 3B and appears at the COMPOSITE BNC connector on the rear panel. The output of IC

3B is also routed to diversity IC 4, IC 9, and to the PRO circuit board. Jumper J5 selects the input to audio amplifiers IC 5A and IC 5B. The factory setting routes the muted audio from IC 4 and IC 9 to the amplifiers, while the alternate setting feeds

unmuted baseband aural directly to the amplifiers. The output of IC 5B is matched for 600 ohms balanced and appears at the MAIN OUT XLR connector at the rear panel.

4.5 PRO Channel Detection

Composite aural from IC 3B on the RF board is routed to the PRO board where it is amplified by Q1 and filtered through a bandpass filter consisting of L1-L4 and C5 through C11. The filtered composite aural is detected in IC 1, a phase-locked loop FM detector. If the PRO subcarrier is present, the inverted C (carrier present) output of IC1 goes low, turning on the PRO CARRIER LED through LED driver U3 on the CPU board. If there is modulation on the PRO subcarrier, the DATA output of IC 1 goes low, turning on the PRO MODULATION LED via LED driver U3 on the CPU board. PRO audio is then amplified by Q3 and sent to the CTCSS decoder.

4.6 CTCSS

The CTCSS section of the PROceiver is located on the PRO board. PRO audio enters PRO decoder chip IC 2. The desired CTCSS tone (or non-CTCSS operation) is selected by grounding the appropriate data inputs through J6. IC 3 provides a 1 MHz clock signal for driving IC 2. During CTCSS operation, the presence of the proper subaudible tone in the PRO audio causes filtered CTCSS audio to appear at the output of IC 2. An on-chip audio filter in IC 2 removes the CTCSS tone and provides communications-grade audio. The receive decode output of IC 2 goes low, toggling switches U2B and U2D. U2B is normally ON and passes full-volume main channel audio. When U2B's control input goes low upon receipt of the proper CTCSS tone, U2B turns the main channel audio OFF. Switch U2D is normally OFF and its output is grounded. When U2D's control input goes low upon receipt of the proper CTCSS tone, the output of U2D is ungrounded and goes high. This high turns on the CTCSS LED and toggles switches U2A and U2C ON. When U2A is ON, "ducked" main channel audio is passed. When U2C is ON, filtered PRO channel audio is passed. Full-volume main channel audio, ducked main channel audio, and filtered PRO channel audio are combined through a network consisting of R32, R33, and R34 and amplified by U1A and U1B. U1A provides a PRO channel feed for headphone amplifier U5 on the CPU board. The output of U1B passes through a 600 ohm audio transformer and appears at the PRO AUDIO OUT XLR connector on the rear panel. An **all-call** CTCSS option, allowing all PROceivers in an ENG/EFM fleet to be activated simultaneously, is available from Modulation Sciences and resides on a separate board.

4.7 Power Supply

The power supply of the PROceiver is simple and straightforward. Power transformer TR1 has dual primary windings which may be connected in parallel for 115 volt operation or in series for 230 volt operation. The 12 VAC output is rectified by bridge rectifier G1, filtered through C1, and regulated to +10 volts by IC1 and C2. The 12 VDC input is also regulated by IC1 and C2 and is protected by diode D1 and a 1 A

fuse. The +10 VDC output of the power supply is regulated to +5.1 VDC by D2 on the PRO board and to +5 VDC by IC 7 on the RF board.

THIS PAGE INTENTIONALLY LEFT BLANK

Chapter 5: Warranty

5.1 Three Years on Parts and Labor

Subject to Modulation Sciences, Inc. warranty policy. Annual calibration fee is not included in warranty. However, any repairs needed during calibration are covered for three years.

5.2 MSI Warranty Policy Summary

NOTE: This is not the warranty. It is a summary of MSI's standard warranty and a description of how to obtain warranty service. The current, actual warranty is printed in its entirety on the following pages and supersedes warranty information which may be found elsewhere.

5.2.1 *Who receives warranty protection?*

Modulation Sciences' standard warranty protects the original end-user purchaser of record but does not apply to subsequent owners.

5.2.2 *What does the warranty cover?*

Modulation Sciences agrees to repair or replace at its expense any unit which has a defect in materials or workmanship for a period of three (3) years after the date of sale to the original end-user purchaser. This warranty includes all parts, labor, calibration, and packing.

5.2.3 *What doesn't the warranty cover?*

MSI's warranty does not cover:

- a) Freight and insurance charges paid by the purchaser in returning the unit for repair.
- b) Defects which result from modifications or repairs to the unit not made by or authorized in writing by Modulation Sciences.
- c) Compensation for incidental or consequential damages resulting from any defect.
- d) Trivial or cosmetic defects which do not affect the unit's ability to function normally.

5.2.4 How is the warranty period computed?

The warranty period begins on the date of delivery.

5.2.5 What if the unit cannot be repaired or is too expensive to repair?

If Modulation Sciences decides not to repair or replace a given unit, Modulation Sciences agrees to refund to the first end-user purchaser its full purchase price. Payment of that amount will end MSI's responsibilities and Modulation Sciences may keep the unit.

5.2.6 How is warranty service obtained?

To claim your rights under this warranty:

- a) Contact the dealer or distributor from whom this product was purchased. Describe the problem and ask if there is an easy solution.
- b) If your dealer cannot help, contact Modulation Sciences' service department at (800) 826-2603 or (732) 302-3090 and explain the problem. If the unit requires factory service, you will be given a return authorization number.
- c) When you have your return authorization number, you may return the unit. Pack it carefully for shipment, preferably using the original shipping carton and packing materials. **ASSUME THAT THE BOX WILL BE DROPPED SEVERAL TIMES DURING SHIPMENT. USE UPS OR SOME OTHER PRIVATE CARRIER YOU KNOW TO BE RELIABLE. DO NOT USE THE POSTAL SERVICE.** The risk of loss is yours. Modulation Sciences will not be responsible for damage or loss until the package is received by Modulation Sciences. **INSURE THE UNIT FOR ITS FULL REPLACEMENT VALUE. SHIP THE UNIT PREPAID TO THE ADDRESS SPECIFIED WHEN YOU RECEIVE THE RETURN AUTHORIZATION AND BE SURE TO ENCLOSE A NOTE GIVING THE FOLLOWING INFORMATION:**
 1. Your company name and shipping address (**not** a P.O. Box).
 2. Your return authorization number.
 3. A copy of your original invoice establishing the starting date of your warranty.
 4. As full a description as possible of the problem(s).

5.3 MSI Warranty Policy

FOR A SUMMARY OF THIS TEXT AND INFORMATION ON OBTAINING WARRANTY SERVICE, PLEASE SEE THE PAGES PRECEDING THIS WARRANTY.

We warrant the equipment sold shall be free from defects in materials and workmanship under normal use and service for a period of three (3) years from the date of delivery when properly installed. Our sole obligation under this warranty shall be limited to repair or replacement, at our option, of any such part or parts of the product which our examination shall disclose to our satisfaction to be defective.

If you wish to have warranty services performed at our facilities, you shall obtain from us, in advance, permission to return the equipment and shall ship it properly packed with transportation and insurance prepaid. Service performed at our facilities under this warranty shall include parts plus labor and normal return shipping. It is expressly agreed that our obligation to repair and replace defective parts is your sole and exclusive remedy.

The warranty to repair or replace defective parts is expressly in lieu of and hereby in disclaimer of all other express warranties and is in lieu of and in disclaimer and exclusion of any implied warranties of merchantability, fitness for particular purpose, as well as all other implied warranties, in law or in equity, and of all obligations or liability on our part. There are no warranties which extend beyond the description hereof.

Our liability does not include any labor charges for replacement of parts, adjustments, repairs, or any work done outside our factory, unless such work is authorized in writing by us. Our obligation to repair or replace shall not apply to any equipment which shall have been repaired or altered outside our factory in any way, subjected to negligence, misuse, unauthorized alteration or abuse, damaged by lightning or other natural calamity, or damaged in transit.

Our liability hereunder shall not include losses of anticipated profits or special incidental or consequential damages.

THIS PAGE INTENTIONALLY LEFT BLANK

Chapter 6: Diagrams

<i>Diagrams</i>	
Block Diagrams	Sections: 6.1, 6.2. 6.3
Schematic Diagrams	Sections: 6.4 → 6.8
Section Interconnects	Section: 6.9
12 VDC Power Connector	Section: 6.10
Pictorial	Section: 6.11
Channel Tuning Chart	Section: 6.12

THIS PAGE INTENTIONALLY LEFT BLANK

6.1 PRO-II PROceiver--Block Diagram--RF and Video Section

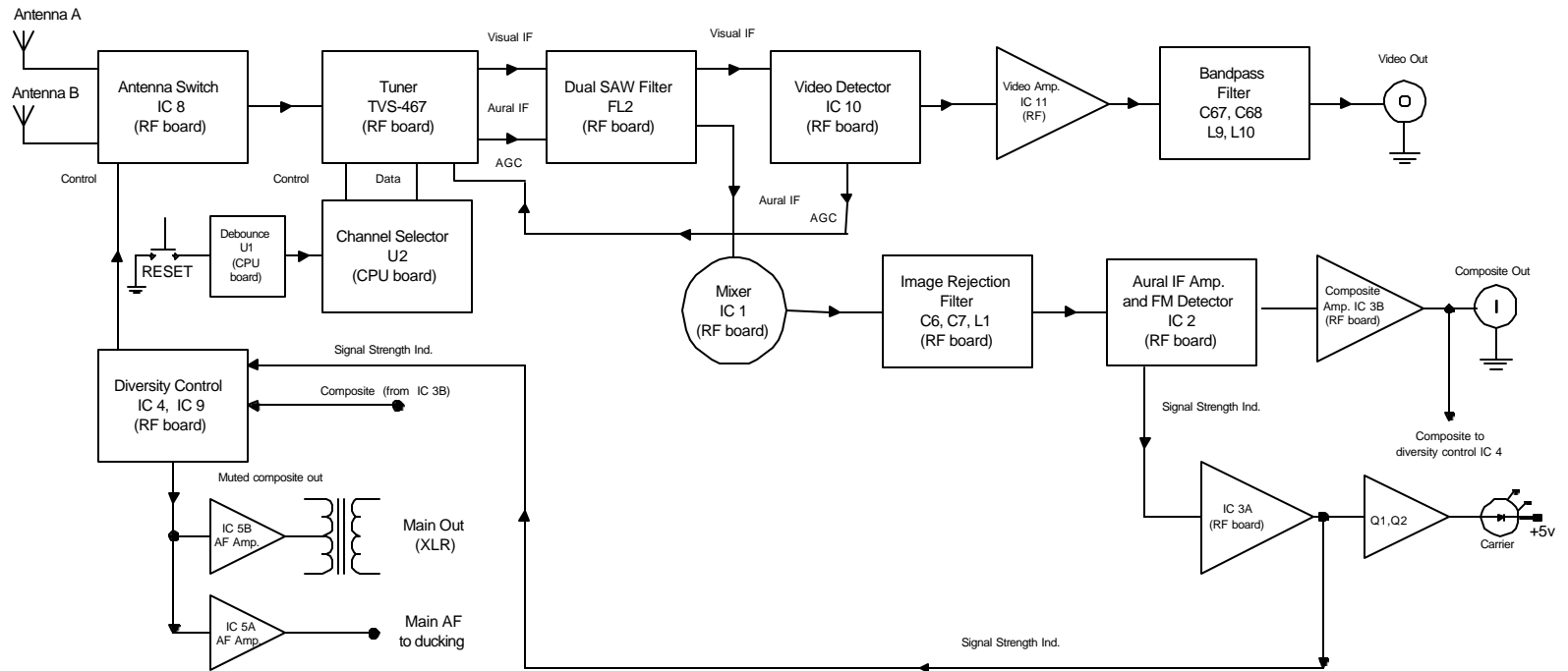

6.2 PRO-II PROceiver--PRO and CTCSS Section Block Diagram

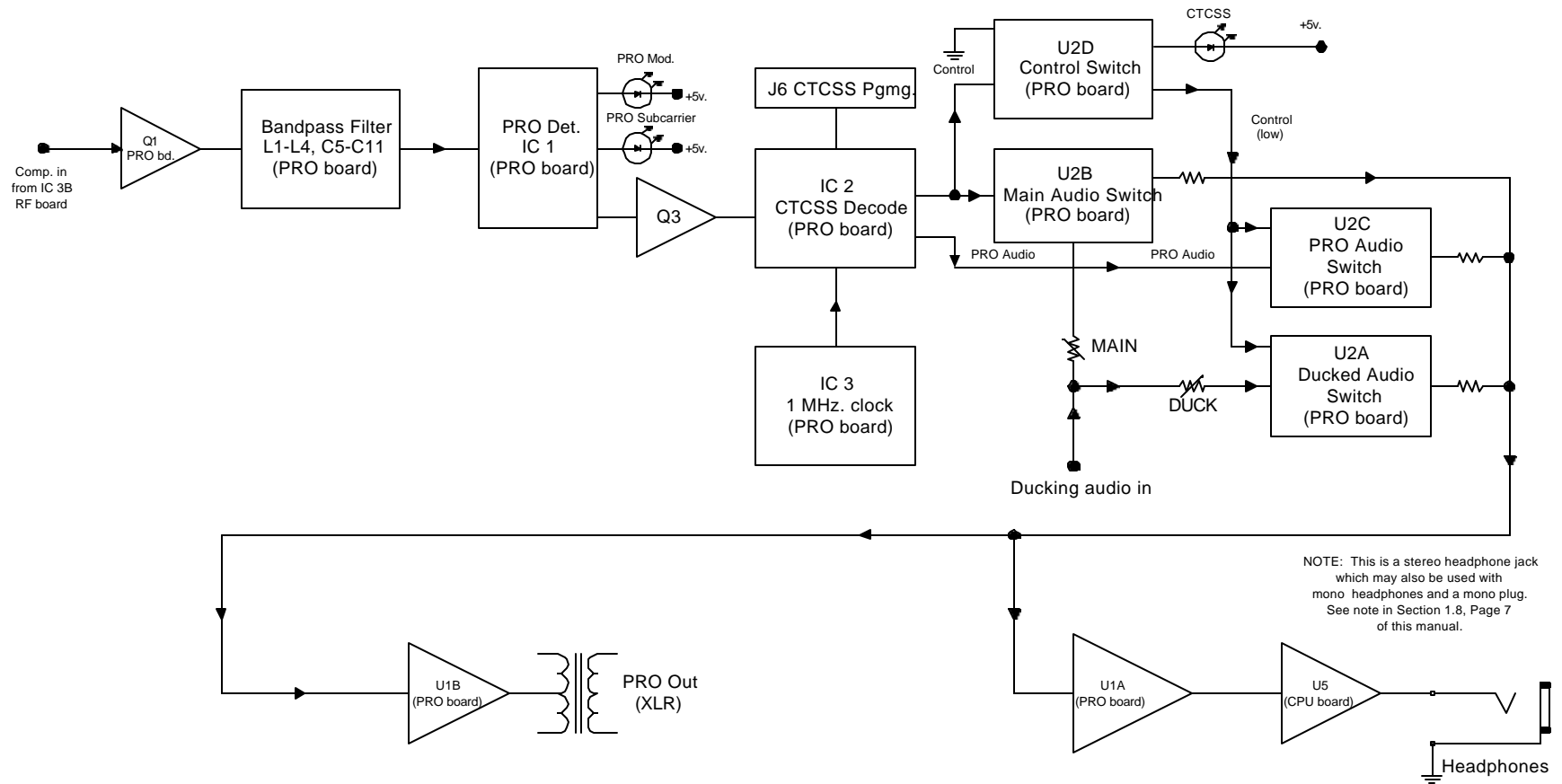

6.3 PRO-II PROceiver Power Supply Schematic

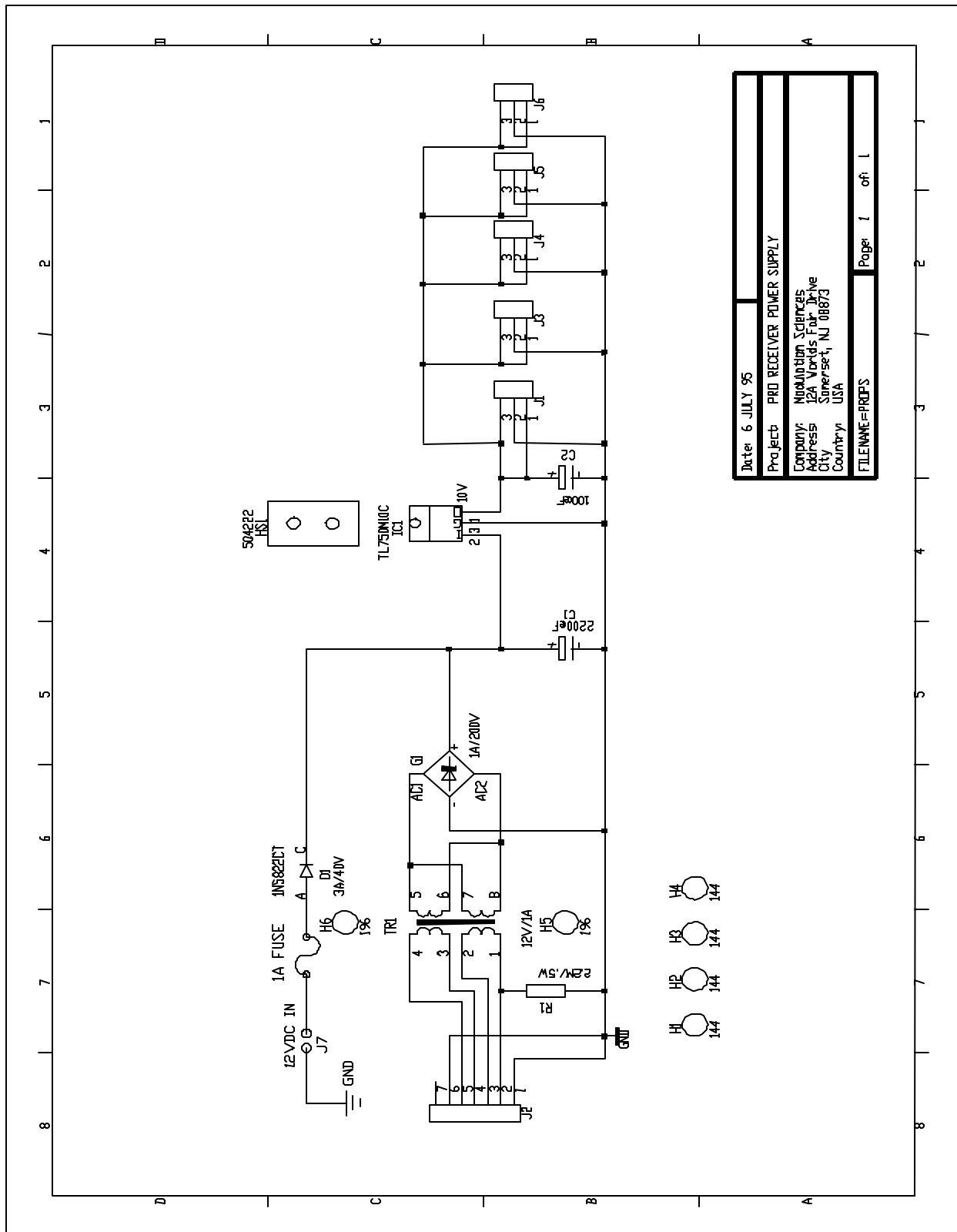

Date: 6 JULY 95	Page: 1 of 1
Project: PRO RECEIVER POWER SUPPLY	
Company: Microlution Sciences	
Address: 12A Yorkids Park Drive	
City: Somerset, NJ 08873	
Country: USA	
FILENAME=PROPS	Page: 1 of 1

6.4 PRO-II PROceiver
Diversity Circuit Schematic

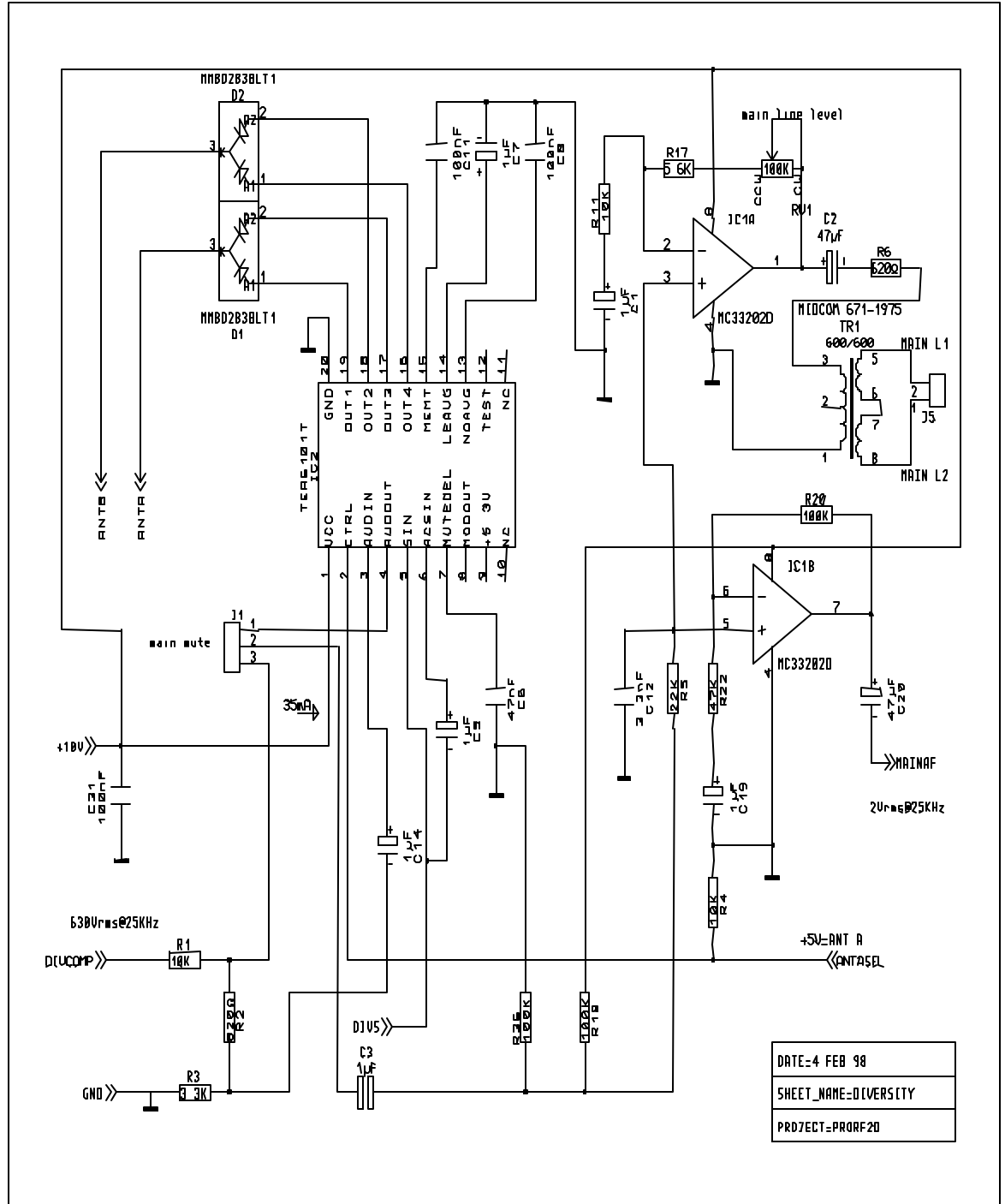

6.6 PRO-II PROceiver
Visual IF Schematic

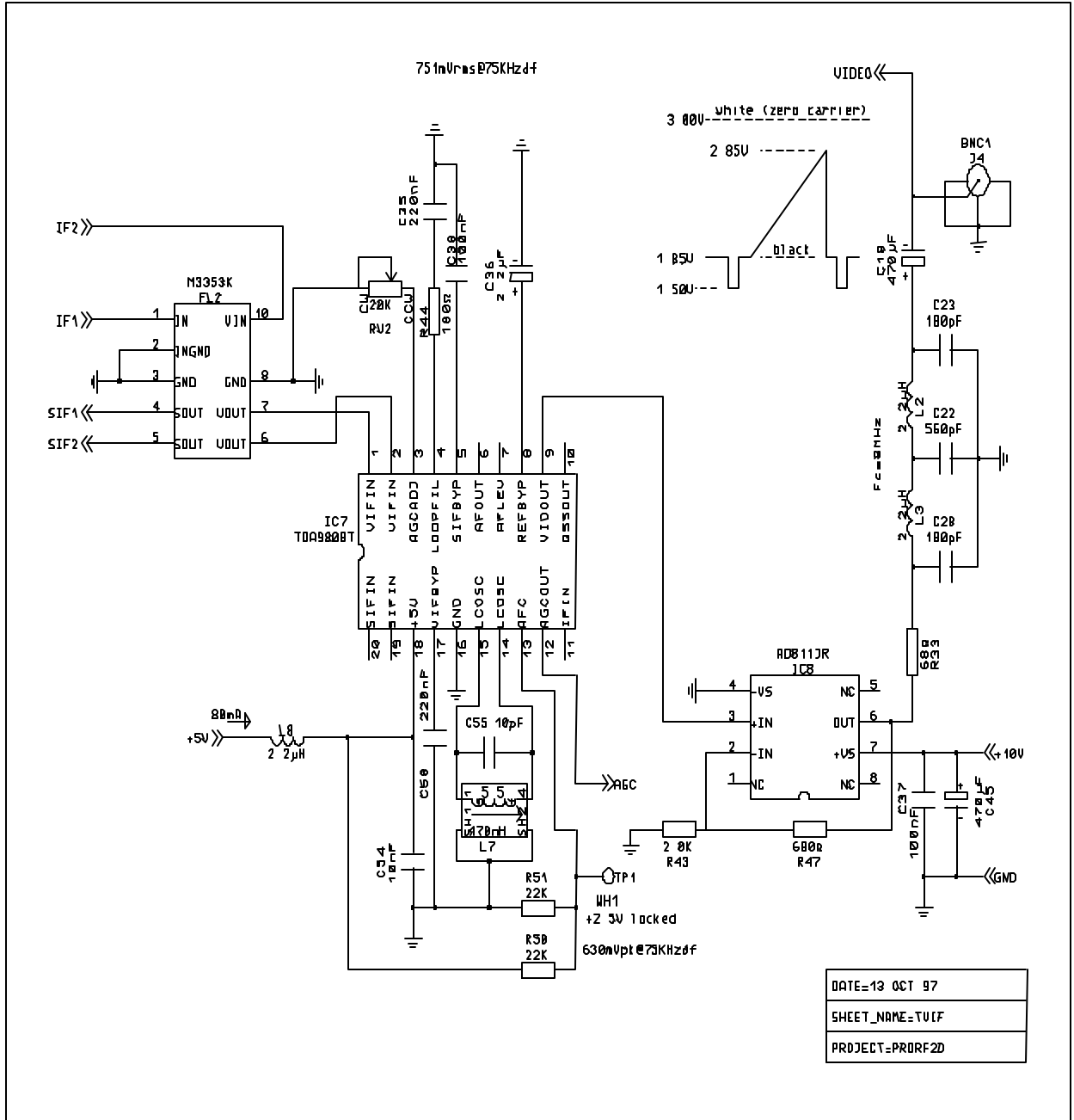

6.7 PRO-II PROceiver Aural IF Schematic

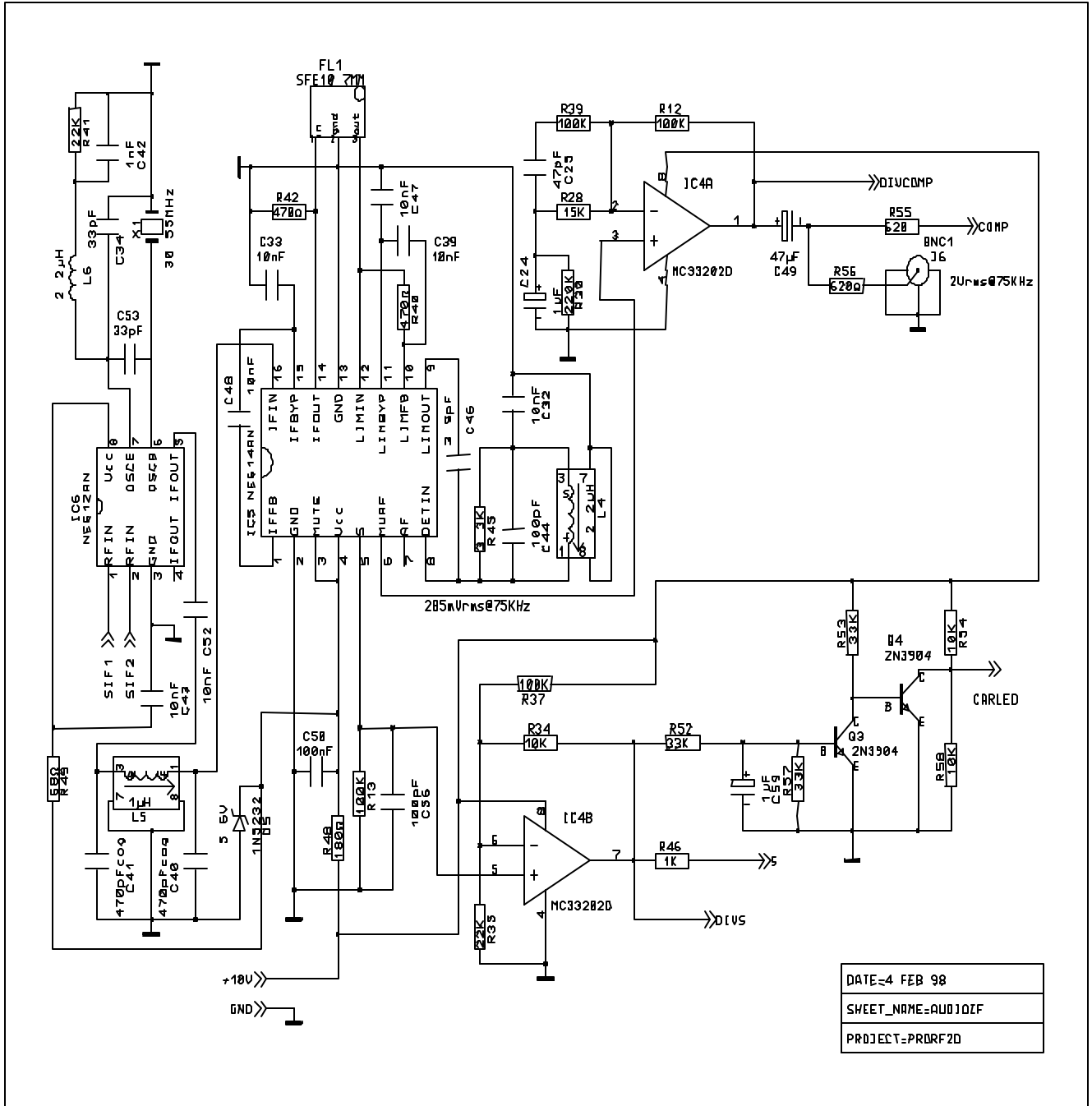

6.8 PRO-II PROceiver
CPU Board Schematic

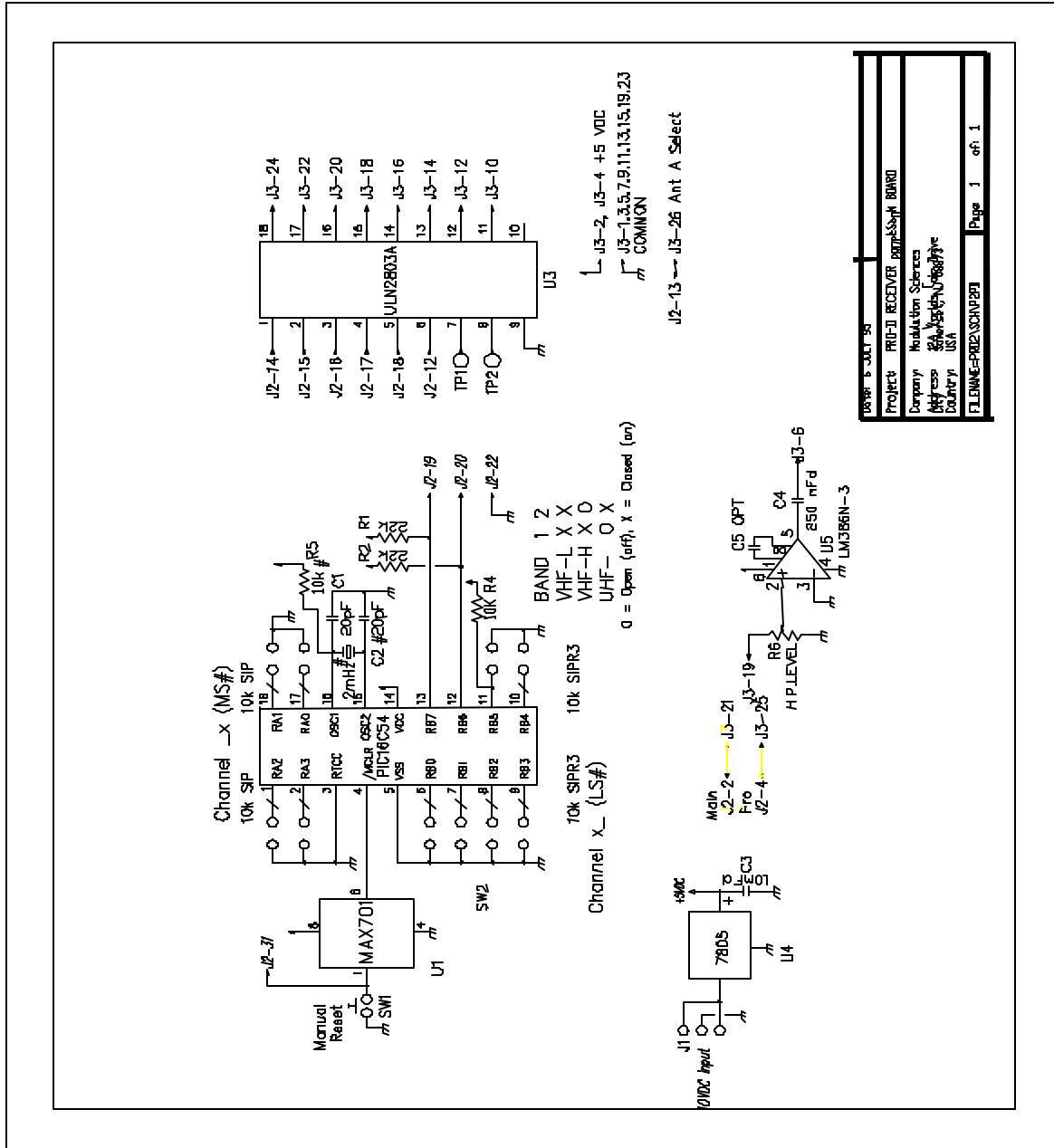

6.10 PRO-II PROceiver
Pinout--12 VDC Power Connector

PROCEIVER II 12VDC CONNECTIVITY GUIDE

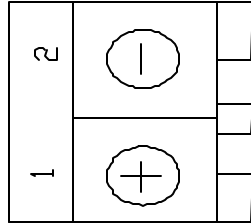

REAR VIEW

Stock No: N/A	Scale: FULL	DRAWING: PR2h 01 05
Material: N/A	Unless otherwise specified:	File: pro2\mech \DCCONDWG
Thickness: N/A	Tolerances:	? 1995 MSI Size: A
Finish: N/A	2 decimal places: ± 0.01	Drawn: PP Date: 10-NOV-95
	3 decimal places: ± 0.005	Appr: Date:
	angles: ± 0.1	Sheet: 1 of 1 Rev: 0
	All Dimensions in inches	Title: PROceiver II DC CONNECTIVITY
	MODULATION SCIENCES, INC.	
	12A Worlds Fair Drive, Somerset, NJ 08873 (908) 302-3090	

6.12 PRO-II PROceiver
Channel Tuning Chart

PROceiver II Channel Tuning Chart
modulation sciences, inc.

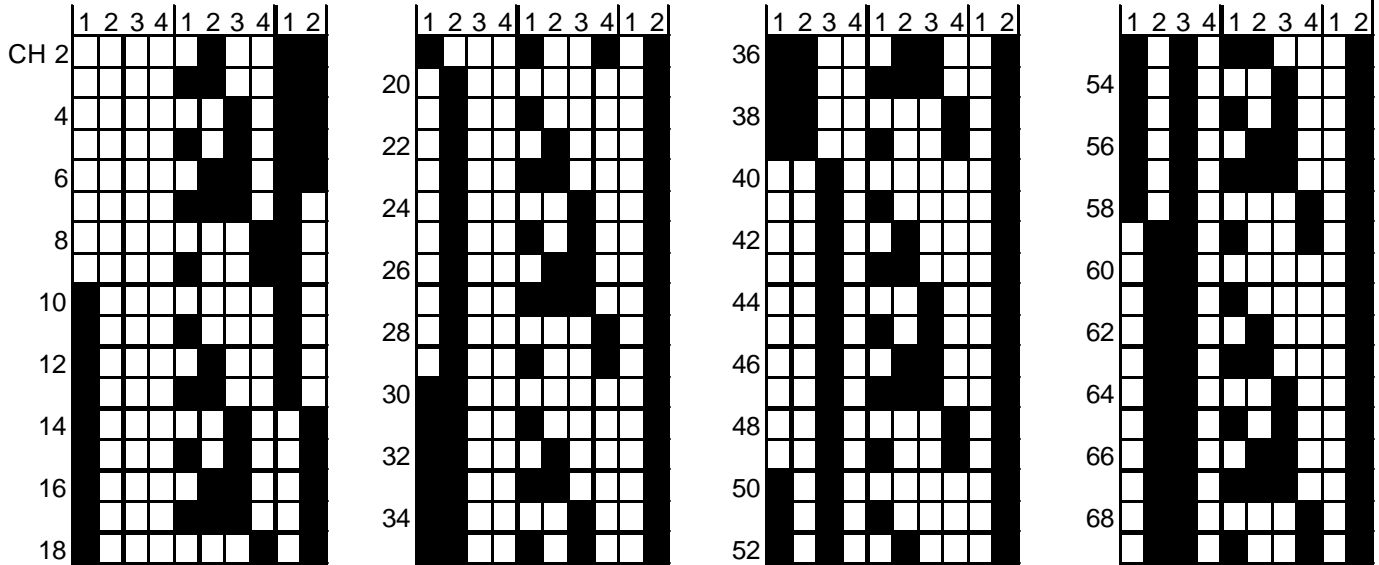

CHANNEL TUNING GUIDE REFERS TO SW2 OF PRO-CPU BOARD. ■ = ON □ = OFF

PROceiver CTCSS Selection Guide

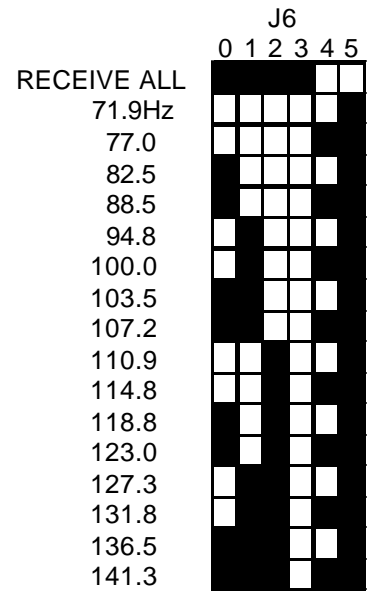

CTCSS TONE SELECTION GUIDE REFERS TO
J6 OF PRO BOARD.

■ = JUMPER ON □ = JUMPER OFF

Chapter 7: Parts Lists

<u>MSI Part Number</u>	<u>Qty</u>	<u>Description</u>	<u>Reference Designators</u>	<u>Manufacturer</u>	<u>Manufacturer Part Number</u>
V01-P2RF					
A02-S106FT002	1	TRIMPOT, 01T 100K FH TOP	RV1	BOURNS	3306P-104
A02-S205FT002	1	20K 1/4" SINGLE TURN ADJUST POT	RV3		
A04-1002JCNG1	1	CAPACITOR, 010P0 CERAMIC 10%	C42	PANASONIC	ECC-F2A100DE
A04-1003JMAF2	1	100pf 100V 5%NPO 6.35mmLS	C9	PANASONIC	ECC-F2A101JCE
A55-1004HCAF1	4	1 nf 1206 50V 5%	C35-C37,C56	PANASONIC	ECU-V1H102JCH
A04-1004HMEG1	1	1000 pf 50 V 5% MC	C40	PANASONIC	ECU-S1J102JCB
A04-1004JCNF1	2	1nf 100V 5% DISC 6.35mmLS	C4,C44	PANASONIC	ECC-F2A102JE
A04-1005FCNI1	8	.01uf 25V+80-20%DISC 6.35mmLS	C1,C5,C11-C15, C71	PANASONIC	ECK-F1E103ZVE
A04-1006HMCH3	4	0.1 uf 63V MC 20% 2.54mmLS	C8,C39,C47,C66	PANASONIC	ECU-S1J104MEA
A04-1006JPNF2	3	0.1uf 50WV POLY5% 5mm	C25,C26,C61	PANASONIC	ECQ-B1H104JF
A04-1007HANH1	6	1uf 50V 20% EL 2mmLS	C19,C20,C21,C28, C30,C31	PANASONIC	ECE-A1HU010
A04-1007HANH2	1	1uf 50V BI-POLAR 20% 2mm	C33	PANASONIC	ECE-A1HN010S
A04-1008HANG1	4	10uf 50V 10% EL 2mmLS	C34,C54-C55	PANASONIC	ECE-A1HU100
A04-1803HMNF1	2	180pf 63V 5% MC 2.54mmLS	C67,C69	PANASONIC	ECU-S1J181JCA
A06-1808F0001	1	18mH INDUCTOR 50kHz 22mA 10RBCASE	L6	181LY-183J	
A04-2204JCNG1	1	2.2nf 100V 10% DISC 6.35mmLS	C38	PANASONIC	ECK-F2A222KBE
A04-2206HFNF1	2	.22uf 50WV POLY 5% 5mm	C60,C65	PANASONIC	ECQ-B1H224JF
A04-2207HANH1	1	2.2uf EL 50V 20% 2mm LS	C70	PANASONIC	ECE-A1HU2R2
A04-2208GANI1	1	22uf 35V RE 20% 0.1 LS	C63	PANASONIC	ECE-A1VU220
A04-3302JCNF1	2	33pf 100V 5% DISC 6.35mmLS	C2,C3	PANASONIC	ECC-F2A330JE
A04-3303JCNF1	1	330pf 100V 5% DISC 6.35mmLS	C16	PANASONIC	ECC-F2A331JE
A04-3304HPNF1	2	3.3nf 50WV POLY 5% 5mm	C23	PANASONIC	ECQ-B1H332JF
A04-4001HCAG1	1	4 pf 50V CER NPO 10% 0.25 LS	C10	MALLORY	CMC040C
A04-4702JCAF1	1	47pf 100V CER NPO 5%	C17	PANASONIC	ECU-S2A470JCA
A04-4703HMCF1	2	470pf 63V 5% MC 2.54mmLS	C6,C7	PANASONIC	ECU-S1J471JCA
A04-4705HPNF1	2	.047uf 50WV POLY 5%5mm	C22,C24	PANASONIC	ECQ-B1H473JF
A04-4708HANG1	5	47uf 50V 10% EL 2.5mmLS	C18,C27,C29,C32, C57	PANASONIC	ECE-A1HU470
A04-4709GANH1	2	470uf 35V 20% EL 5mmLS	C48,C50	PANASONIC	ECE-A1VU471
A04-5603JCNF1	1	560pf 100V 5% DISC 6.35mmLS	C68	PANASONIC	ECC-F2A561JE
A06-1004T0001	1	1uH ADJ RF CHOKE 10mm	L1	TOKO	BTKXNS-T1050Z
A06-1505F0001	1	15uH 0.5"LS	L7	WILCO	ML150

A06-1693T0001	1	169 nH MOLDED COIL MC120	L8	TOKO	E526HNA-100298
A06-2204F0001	3	2.2 uH 0.5"LS ON PLASTIC FORM	L3,L9,L10	WILCO	ML22G
A06-2204T0001	1	2.2uH SHIELDED VARIABLE COIL	L2	TOKO	BTKANS-9447HM
A07-6711975	1	671-1975 TRANSFORMER MIDCOM AUDIO 1:1	TR1	MIDCOM	671-1975
A10-305500001	1	30.55 MHz 3rd Overtone 20pf HC-18 / 50 ppm	X1	JAN	
A10-TVS467	1	TUNER	TU1	MAGNAVOX	TVS467
B01-4148	5	GLASS DIODE	D2-D6	VARIOUS	1N4148
B01-5232	1	5.6V ZENER DIODE 0.4"LS	D1	VARIOUS	1N5232
B01-5256	1	30V ZENER DIODE 0.4"LS	D8	VARIOUS	1N5256
B04-N3904	5	TRANSISTOR TO 92	Q1,Q2,Q3,Q6,Q7	NPN	2N3904
C01-MC33202	2	DUAL OP AMP	IC3,IC5	MOTOROLA	MC33202P
C02-1P501M003	1	+5V 1AMP TO226 REG.	IC7	MOTOROLA	LM7805CT
C99-10.7MX2-A	1	IF FILTER	FL1	MURATA	SFE10.7MX2-A
C99-AD811AN	1	VIDEO OP AMP DIP PKG	IC11	ANALOG DEVICES	AD811AN
C99-TDA9808N	1	TV VIDEO SOUND DEMODULATOR DIP	IC10	PHILIPS	TDA9808N
C99-TEA6101TD	1	ANTENNA DIVERSITY, SMT PKG	IC4	PHILIPS	TEA6101TD
D05-M3353K	1	SAWFILTER 45.75 MHZ VIDEO & SOUND	FL2	SIEMENS	M3353K
D05-NE612AN	1	RF MIXER PLASTIC	IC1	PHILIPS	NE612AN
D05-NE614AN	1	IF AMP DETECTOR PLASTIC	IC2	PHILIPS	SA614AN
D05-SW239PIN	1	RF SWITCH SURFACE MOUNT	IC8	MACOM	SW239PIN
G04-P2RF	1	PWB PRO2 RF REV C			
H02-002F00009	4	BNC RIGHT ANGLE PC MNT METAL	J6,J7,J8,J9	AMP	227661-1
H02-002M00003	1	MALE PHONO PLUG	JC1		
H08-001PMW001	11	SINGLE WW PIN	CHASSIS		
H08-002PMS001	1	MASCON 2-PIN LATCH HEADER W/GOLD	J4	PANDUIT	MLSS100-2-CB
H08-003PMS001	1	MASCON 3-PIN LATCH HEADER W/GOLD	J3	PANDUIT	MLSS100-3-CB
H08-1X3HEADER	1	3PIN,UNLATCH HEADER 0.1"	J5	PANDUIT	MFSS100-3-DB
H08-2X25HEADR	1	SHROUDED HEADER 2X25 LATCHED 0.1"	J2	PANDUIT	50-50-133A
H19-002000001	1	0.1` WW PIN JUMPER		BERG	65474-001
J03-P249X0001	2	WHITE 24 AWG STRANDED HOOK-UP WIRE	JC1		
K03-S00000001	1	T03 HEAT SINK (Hosfelt Elec.)	IC7	THERMALLOY	6079
K99-4026	4	TAPE, DOUBLE SIDE, 1" SQUARE	TU1		
Z01-000	1	0 OHM 1/4W 5% CF	R8		
Z01-103	1	100 OHM 1/4W 5% CF	R2		
Z01-104	3	1K 1/4W 5% CF	R16,R41,R46		
Z01-105	7	10K 1/4W 5% CF	R13,R28,R34, R60-R62,R64		
Z01-106	8	100K 1/4W 5% CF	R4,R10,R15, R24-R26,R32,R63		
Z01-155	2	15K 1/4W 5% CF	R9,R19		
Z01-183	1	180 OHM 1/4W 5% CF	R72		
Z01-186	1	180K 1/4W 5% CF	R21		
Z01-204	1	2 K 1/4W 5% CF	R78		
Z01-223	1	220 OHM 1/4W 5% CF	R7		

Z01-224	1	2.2K 1/4W 5% CF	R42		
Z01-225	5	22K 1/4W 5% CF	R1,R14,R27,R76, R77		
Z01-226	1	220K 1/4W 5% CF	R11		
Z01-274	2	2.7 K 1/4W 5% CF	R30-R31		
Z01-333	1	330 OHM 1/4W 5% CF	R45		
Z01-334	2	3.3K 1/4W 5% CF	R3,R38		
Z01-335	4	33K 1/4W 5% CF	R17,R18,R20,R22		
Z01-473	3	470 OHM 1/4W 5% CF	R5,R6,R73		
Z01-474	3	4.7K 1/4W 5% CF	R36,R40,R47		
Z01-564	1	5.6K 1/4W 5% CF	R39		
Z01-623	2	620 OHM 1/4W 5% CF	R23,R29		
Z01-682	1	68 OHM 1/4W 5% CF	R80		
Z01-683	1	680 OHM 1/4W 5% CF	R79		
Z01-823	1	820 OHM 1/4W 5% CF	R35		
Z01-824	1	8.2K 1/4W 5% CF	R37		
Z02-1005	1	10.0 K 1/4W 1% MF	R12		
Z02-1006	1	100 K 1/4W 1% MF	BACK OF BOARD		
Z02-2215	1	22.1K 1/4W 1% MF	BACK OF BOARD		
Z52-10041206	2	1K OHM 1206 1% 1/8W RESISTOR	R43,R44	PANASONIC	ERJ-8GEYJ1.0KV
V01-P2PB					
A02-S105FT002	1	TRIMPOT, 01T 10K0 FH TOP	R6	BOURNS	3306P-103
A04-1008HANG1	1	10uf 50V 10%EL 2mmLS	C3	PAN	ECE-A1HU100
A04-2202UCCH1	1	22 pf DISC	C2	SPR	10TSQ22
A04-2209FANI1	1	220 uf 25V EL	C4	PAN	ECE-A1EU221
C01-LM386N	1	LOW VOLT AUDIO PWR AMP	U5	NSC	LM386N-3
C02-1P501M001	1	+5VDC 1.5 AMP REG TO-220 PKG.	U4	NSC	LM340T-5
D01-ULN2803A	1	LED DRIVER	U3	MOT	ULN2803A
D05-701CPA	1	POWER ON RESET, PLASTIC DIP	U1	MAXIM	MAX701CPA
D07-PIC16C54R	1	IMBEDDED MICRO CNTRL	U2	MICROCHIP	PIC16C54RC
H05-018000002	1	18 PIN FACE GRIP SS	U2	AMP	2-641263-20
H08-003PMS001	1	MASCON 3-PIN LATCH HEADER W/GOLD	J1	PANDUIT	MLSS100-3-CB
H08-026PMS002	1	26-PIN SHROUDED HEADER W/LATCH	J3	PANDUIT	50-26-133A
H08-2X25HEADR	1	SHROUDED HEADER 2X25 LATCHED 0.1"	J2	PANDUIT	50-50-133A
I01-EVQPBC07K	1	PUSHBUTTON SWITCH	SW1		
I02-LD10HOK	1	10 POS SEALED DIP SWITCH	SW2	C&K	LD10H0K
Z02-1005	2	10.0 K 1/4W 1% MF	R4,R5		
Z02-2215	2	22.1K 1/4W 1% MF	R1,R2		
Z20-100509S01	1	9 X 10K SIP			
V01-PR2M					
A02-S104FT002	2	TRIMPOT, 01T 1K00 TOP	RV3,RV4	BOURNS	3306P-102
A02-S105FT002	1	TRIMPOT, 01T 10K0 FH TOP	RV1	BOURNS	3306P-103

A02-S506FT001	1	TRIMPOT, 01T 500K FS TOP	RV2	BOURNS	3306P-504
A04-1006HMCH3	9	0.1 uf 63V MC 20% 2.54MM LS	C29,C3,C4,C12, C15,C20-C23	PANASONIC	ECU-S1J104MEA
A04-1006JPNF2	3	0.1uf 50WV POLY 5% 5MM	C25,C26,C32	PANASONIC	ECQ-B1H104JF
A04-1007HANH1	6	1uf 50V 20% EL 2mmLS	C13,C24,C27,C28, C30,C31	PANASONIC	ECE-A1HU010
A04-1008HANG1	2	10uf 50V 10% EL 2mmLS	C1,C36	PANASONIC	ECE-A1HU100
A04-1009HANH1	1	100 uf 50V EL 20% 3.5MM LS	C17	PANASONIC	ECE-A1HU101
A04-1803HMNF1	1	180pf 63V 5% MC 2.54mmLS	C6	PANASONIC	ECU-S1J181JCA
A04-2203HMNF1	1	220pf 63V 5% MC 2.54mmLS	C7	PANASONIC	ECU-S1J221JCA
A04-2204HMNF1	4	2200pf 63V 5% MC 5.08mmLS	C5,C9-C11	PANASONIC	ECU-S1J222JCB
A04-3302JCNF1	2	33pf 100V 5% DISC 6.35mmLS	C34,C35	PANASONIC	ECC-F2A330JE
A04-3303HMNF1	1	330pf 63V 5% MC 2.54mmLS	C16	PANASONIC	ECU-S1J331JCA
A04-3303JCNF1	1	330pf100V5% DISC 6.35mmLS	C19	PANASONIC	ECC-F2A331JE
A04-3903HMNF1	1	390pf 63V 5% MC 2.54mmLS	C8	PANASONIC	ECU-S1J391JCA
A04-3904JCNF1	1	3.9 nf 100V CER 10% 6.35MM	C14	PANASONIC	ECC-F2A392KBE
A04-4708HANG1	1	47uf 50V 10% EL 2.5mmLS	C33	PANASONIC	ECE-A1HU470
A04-6803JCNF1	1	680 pf 100V 5% DISC 6.35mmLS	C18	PHILIPS	D681J59U2MHAAAC
A04-6805HPNF1	1	0.068uf 50WV POLY 5% 5mmLS	C37	PANASONIC	ECQ-B1H683JF
A06-1007T0001	4	1 mH MINI SHIELDED COIL	L1-L4	TOKO	126ANS-T1094Z
A07-6711975	1	671-1975 TRANSFORMER MIDCOM AUDIO 1:1	TR1	MIDCOM	671-1975
A10-040000001	1	4.000 MHz CRYSTAL	X1	ACCORD	
B01-4148	2	GLASS DIODE	D1,D3	VARIOUS	1N4148
B02-1N5231	1	5.1V ZENER DIODE 0.4"LS	D2	VARIOUS	1N5231
B04-4124	3	TRANSISTOR,TO226	Q1,Q2,Q3	VARIOUS	2N4124
C01-MC33202	1	DUAL OP AMP	U1	MOTOROLA	MC33202
C01-MX165CP	1	TONE DECODER, PLASTIC	IC2	MX-COM	MX165CP
C01-XR2211	1	PHASE LOCKED LOOP	IC1	EXAR	XR2211
D01-4066X0001	1	QUAD ANALOG SWITCH	U2	HARRIS	CD4066BE
D01-CGS3322M	1	OCS/DRIVER SURFACE MOUNT	IC3	NATIONAL	CGS3322M
H08-002PMS001	1	MASCON,2-PIN LATCH HEADER W/GOLD	J3	PANDUIT	MLSS100-2-CB
H08-002PMW002	1	2 PIN WW STRIP	J1	SAMTEC	TSW-102-07-GS
H08-003PMS001	1	MASCON 3-PIN LATCH HEADER W/GOLD	J4	PANDUIT	MLSS100-3-CB
H08-2X25HEADR	1	SHROUDED HEADER 2X25 LATCHED 0.1"	J2	PANDUIT	50-50-133A
H08-6X2HEADR	1	2X6 HEADER 0.1"	J6	SULLINS	PZC6DAAN
H19-002000001	6	0.1" WW PIN JUMPER	J6	BERG	65474-001
L03-PWBSERLAB	1	PWB SERIAL LABEL (KAPTON)		CRITCHELY	CR3-KG10F
Z01-103	1	100 OHM 1/4W 5% CF	R6		
Z02-1005	4	10.0 K 1/4W 1% MF	R7,R11,R23,R38		
Z01-106	4	100K 1/4W 5% CF	R13-R14,R22,R31		
Z01-107	1	1 M 1/4W 5% CF	R20		
Z01-224	1	2.2K 1/4W 5% CF	R35		
Z01-226	1	220K 1/4W 5% CF	R24		

Z01-227	1	2.2 M 1/4W 5% CF	R16		
Z01-275	1	27 K 1/4W 5% CF	R5		
Z01-305	2	30K 1/4W 5% CF	R12,R15		
Z01-335	3	33K 1/4W 5% CF	R32,R33,R34		
Z01-336	1	330 K 1/4W 5% CF	R25		
Z01-394	2	3.9 K 1/4W 5% CF	R4,410		
Z01-474	1	4.7K 1/4W 5% CF	R3		
Z01-475	4	47 K 1/4W 5% CF	R1,R17,R27,R29		
Z01-566	1	560 K 1/4W 5% CF	R19		
Z01-623	2	620 OHM 1/4W 5% CF	R2,R28		
Z01-684	1	6.8 K 1/4W 5% CF	R30		
Z01-685	1	68 K 1/4W 5% CF	R8		
Z02-2435	1	24.3K 1/4W 1% MF	R9		
Z02-2874	1	2.87 K 1/4W 1% MF	R18		
Z09-223	1	220 OHM 1/2W 5% CF	R21		
V02-PR2H					
A09-S3AG02501	1	FUSE, SLOW-BLOW, 1/4 AMP			
H02-003F00002	1	1/4" PHONE JACK, STEREO		SWITCHCRAFT	MT332B
H02-003M00001	2	3 PIN M PANEL MT XLR CONNECTOR Switchcraft# D3M	J4A, J3A	SWITCHCRAFT	D3M
H08-002CFW001	3	2 PIN FEM END CONNECTOR W/GOLD	J2,J3,J4		
H08-002CFW002	1	2 PIN .156" END CONNECTOR W/GOLD	J7	PANDUIT	CE156F20-2
H08-003CFW001	6	3 PIN CM END CONNECTOR W/GOLD PL		PANDUIT	CE100F24-3
H08-005CFW002	1	5 PIN .156" END CONN. W/GOLD	J2	PANDUIT	CE156F20-5
H08-03121026	1	2 PIN FEMALE PWR CONNECTOR		MOLEX	3-12-1026
H08-031220210	1	DC CONNECTOR, 2 PIN (SHELL)	J7A	MOLEX	3/12/2025
H08-18121222 ?	2	TERM PIN, FEMALE 16-18 AWG		MOLEX	18-12-1222
H08-M18122222 ?	2	TERM PIN, MALE, 16-18 AWG	J7A	MOLEX	18-12-2222
H10-025F00006	1	D-SUB 25 PIN FEM PANEL MOUNT	AUX	AMP	747913-2
H99-003000001	1	POWER INPUT MODULE CORCOM 6J4	J2A	CORCOM	6J4
J01-200000001	2	NO. 20 AWG BUS WIRE TINNED	J3AG TO J3AP1, J4AG TO J4AP1	MCMaster-CARR	8871 K37
J03-P200X0001	162	20AWG BLACK STRANDED HOOK-UP WIRE	J7AP2 TO J7P1, J2AF - J2P4, J2AL		
J03-P202X0001	12	RED 20AWG STRANDED HOOK-UP WIRE	J7AP1 - J7P2, J2AE - J2P2		
J03-P203X0001	9	ORANGE 20AWG STRANDED WIRE	CORCOM TO J2		
J03-P205X0001	114	GREEN 20AWG STRANDED HOOK-UP WIRE	J7A TO J7P1		
J03-P206X0001	114	LT BLUE 20 AWG STRANDED HOOK-UP WIRE	J7AN TO J7AJ		
J03-P248X0001	114	GREY 24AWG STRANDED HOOK-UP WIRE			
J03-P240X0001	35	Black 24 AWG STRANDED HOOK-UP WIRE, UL1007			
J03-P242X0001	70	RED 24 AWG STRANDED HOOK-UP WIRE			
J03-P24910001	4	WHITE/BROWN STRIPED 24AWG	J3AP2 TO J3P2		
J03-P24950001	4	WHITE/GREEN STRIPED 24 AWG	J3AP3 TO J3P1		

J03-P24960001	10	WHITE/BLUE STRIPED 24 AWG	J4AP3 TO J4P1		
J03-P24970001	10	WHITE/VIOLET STRIPED 24 AWG	J4AP2 TO J4P2		
J07-P18000005	1	POWER CORD 2.3 METER THIN LINE			535
K02-000000005	3	.250 ID INSULATING (BLACK)	TOP COVER	HEYCO	2810
K04-883	4	#6 1/8" NYLON RND SPACER		KEYSTONE	883
K06-H3510NT90	2	5 1/2 INCH LONG CABLE TIE		VISION	NCT055
K06-pfCCAC8	1	ADHESIVE CABLE MOUNTS		PANDUIT	FCC-A-C8
K09-H10SCL001	1	`D` SUB SCREWLOCK-SET OF 2 PCS			
L03-MYBHEAR	1	SET OF RACK EARS, A LEFT AND A RIGHT		JETPREC	CUSTOM
L03-P2PBINSUL	1	PROC INSUL (.01" CLEAR LEXAN)		APEXX	
L03-PR2MINSUL	1	PR2M INSUL (.01" CLEAR LEXAN)		APEXX	
L03-PRO2PSINS	1	POWER SUPPLY INSULATOR			
N01-000000002	1	LOCTITE 242 THREAD LOCK		LOCTITE	242
V05-PRO2CABLE	1	26 IN. 50 CONDUCTOR FLAT CABLE ASSEMBLY PRO-II			
V03-P2FP					
E01-S20000001	1	RED LED	LD5	DIALIGHT	521-9240
E01-S40000001	3	YELLOW LED	LD2,LD4,LD6	DIALIGHT	521-9176
E01-S50000001	2	GREEN LED	LD1,LD3	DIALIGHT	521-9270
G04-P2FP	1	PWB, PRO2 FRONT PANEL, REV B		CIRCUIT REPRO	
H08-002PMS001	1	MASCON, 2-PIN LATCH HEADER W/GOLD	J1	PANDUIT	MLSS100-2-CB
H08-026CFC003	1	26 PIN LATERAL NO STRAIN RELIEF	J1	PANDUIT	50-A26-455
H08-34340000T	1	26 P LOW PROFILE PWB CONN	J1	3M	3434-0000T
I02-010100207	1	MOM PUSH SWITCH PC MNT W/BRACK	SW2	ALCO	MPS-103F-PCV
I02-A1010SYCQ	1	SPDT TOGGLE SWITCH, PC MNT	SW1	SWITCHCRAFT	A1010SYCQE
J06-N026P2801	10	26-COND FLAT CABLE / PER INCH	J1	3M	3365-26
K01-I02CAP001	1	CAP, SWITCH	SW2	ALCO	C22-BLACK
K02-ELM421MM	6	LED SPACER, 0.827"	LD1-LD6	BIVAR	ELM421MM
L03-PWBSERLAB	1	PWB SERIAL LABEL (KAPTON)		CRITCHELY	CR3-KG10F
Z20-220307S01	1	7 X 220 SIP	R1		
V03-P2PS					
A04-1009HANH1	1	100 uf 50V EL 20% 3.5mmLS	C2	PANASONIC	ECE-A1HU101
A04-680ADANH1	1	6800uf 16V 20% AE AXIAL	C1		
A08-LP25500	1	PWR TRANSF.120/220/12V	TR1	SIGNAL	LP24-500
A09-F3AG10001	1	FUSE, FAST-BLOW, 1 AMP		LITTELFUSE	312001
B01-5822	1	SCHOTTKY DIODE	D1		
B03-B7000	1	BRIDGE RECT. 1 AMP	G1	GEN INSTRMNT	DF02MG1
C02-TL750M10C	1	10V REG. TO220	IC1	TI	TL750M10C
G04-P2PS	1	PWB, PRO2 POWER SUPPLY			
H04-4245	1	FUSE HOLDER, PC MOUNT 3AG		KEYSTONE	4245
H08-002PMS002	1	2 PIN LOCK HEADER .156" LSGOLD	J7	PANDUIT	MLSS156-2-CB
H08-003PMS001	5	MASCON 3-PIN LATCH HEADER W/GOLD	J1,J3-J6	PANDUIT	MLSS100-3-CB

H08-005PMS002	1	5 PIN LOCK HEAD .156" LS GOLD	J2	PANDUIT	MLSS156-5-CB
K03-00002	1	HEAT SINK BLACK ANODIZED FINISH	HS1	AAVID	504222 B00000
K06-D08477	1	11` LADDER CABLE TIE	TR1		
L03-PWBSERLAB	1	PWB SERIAL LABEL (KAPTON)		CRITCHELY	CR3-KG10F
O03-4/40E2501	2	4/40X1/4 SEMS, PHILIPS PAN HEAD	HS1		
O03-4/40N0002	2	4/40 SMALL HEX NUT	HS1		
Z01-227	1	2.2 M 1/4W 5% CF	R1		